

Walther Engineering and Manufacturing Co., Inc.

Part Number	Application	Standout	Lbs.	Bolts
Easy-Roll™ Trailer Hub (TN Axle)				
10-00106-001	Hub Piloted/Aluminum Dual Wheel	3.96"	44	02-00045
10-00106-002	Hub Piloted/Steel Dual Wheel	3.03"	42	02-00044
10-00106-003	Stud Piloted RH/Cast Brake Drum	1.88"	39	02-00057
10-00106-004	Stud Piloted LH/Cast Brake Drum	1.88"	39	20-00058
10-00106-005	Stud Piloted RH/Fused Brake Drum	1.63"	39	02-00061
10-00106-006	Stud Piloted LH/Fused Brake Drum	1.63"	39	20-00062
10-00106-101	ABS Hub Piloted/Aluminum Dual Wheel	3.96"	45	02-00045
10-00106-102	ABS Hub Piloted/Steel Dual Wheel	3.03"	42	02-00044
10-00106-103	ABS Stud Piloted RH/Cast Brake Drum	1.88"	40	02-00057
10-00106-104	ABS Stud Piloted LH/Cast Brake Drum	1.88"	40	20-00058
10-00106-105	ABS Stud Piloted RH/Fused Brake Drum	1.63"	40	02-00061
10-00106-106	ABS Stud Piloted LH/Fused Brake Drum	1.63"	40	20-00062

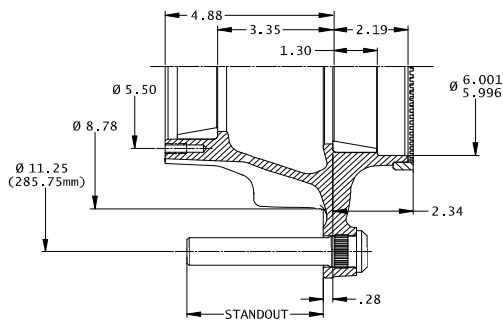

Part Number	Application	Standout	Lbs.	Bolts
Easy-Roll™ Trailer Hub (TN Axle) with 16.5 x 7" Cast Drum				
1001106-031043*	Hub/Cast Drum Assy,HP,AL Whl	3.54"	153	02-00045
1001106-032043*	Hub/Cast Drum Assy,HP,ST Whl	2.61"	151	02-00044
1006106-033043	Hub/Cast Drum Assy,SP,RH	1.46"	148	02-00057
1007106-034043	Hub/Cast Drum Assy,SP,LH	1.46"	148	20-00058
1001106-131043*	ABS Hub/Cast Drum Assy,HP,AL Whl	3.54"	154	02-00045
1001106-132043*	ABS Hub/Cast Drum Assy,HP,ST Whl	2.61"	152	02-00044
1006106-133043	ABS Hub/Cast Drum Assy,SP,RH	1.46"	149	02-00057
1007106-134043	ABS Hub/Cast Drum Assy,SP,LH	1.46"	149	20-00058

* Includes two flanged wheel nuts

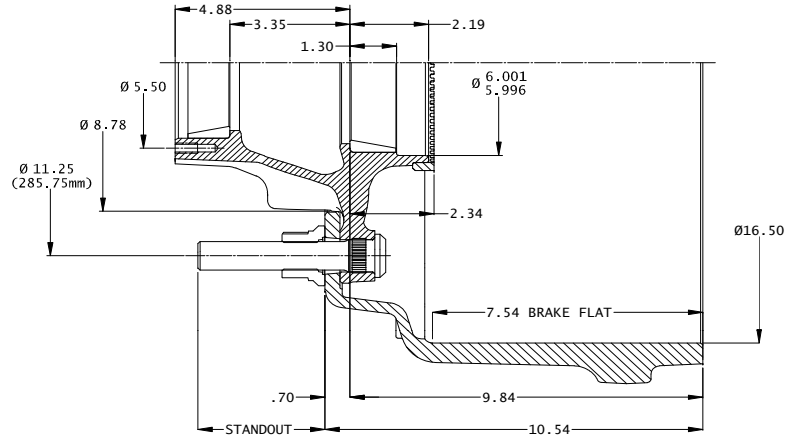

ALL WEIGHTS ARE BASED ON NOMINAL COMPONENT WEIGHT

TN Bearings	
HM212011	bearing cup - outer bore
HM218210	bearing cup - inner bore
HM212049	bearing cone - outer bore
HM218248	bearing cone - inner bore

Drums		
03-00043	16.5 x 7" Cast Brake Drum	108 lbs
89996B	16.5 x 7" Centrifuse® Brake Drum	90 lbs

Component Parts		
WN333T	Okabe - Two-piece, Flanged Wheel Nut,M22x1.5	.4 lbs
02-39702	Metform - Two-piece, Flanged Wheel Nut,M22x1.5	.4 lbs

Hub Dynamic Load Ratings	
Wheel Offset	Load/Hub
0	11,250 lbs
0.56"	10,839 lbs
2.00"	10,000 lbs
2.38"	9,689 lbs
2.75"	9,484 lbs
3.50"	9,095 lbs
3.88"	8,910 lbs
6.66"	N/A

Lubricant Fill Volumes	
20.88 fl-oz	Oil Lubrication Fill Level
94.65 in³	Vol. Between Cup Seats Including Spindle Displacement
26.22 fl-oz	50% Fill Level for Semi-Fluid, Including Spindle Displacement

Easy-Roll™ Trailer Hub (TN Axle) with 16.5 x 7" Centrifuse® Brake Drum				
1001106-041095*	Hub/Fused Drum Assy,HP,AL Whl	3.71"	135	02-00045
1001106-042095*	Hub/Fused Drum Assy,HP,ST Whl	2.78"	133	02-00044
1006106-045095	Hub/Fused Drum Assy,SP, RH	1.38"	129	02-00061
1007106-046095	Hub/Fused Drum Assy, SP,LH	1.38"	129	20-00062
1001106-141095*	ABS Hub/Fused Drum Assy,HP,AL Whl	3.71"	136	02-00045
1001106-142095*	ABS Hub/Fused Drum Assy,HP,ST Whl	2.78"	134	02-00044
1006106-145095	ABS Hub/Fused Drum Assy,SP,RH	1.38"	130	02-00061
1007106-146095	ABS Hub/Fused Drum Assy,SP,LH	1.38"	130	20-00062

* Includes two flanged wheel nuts

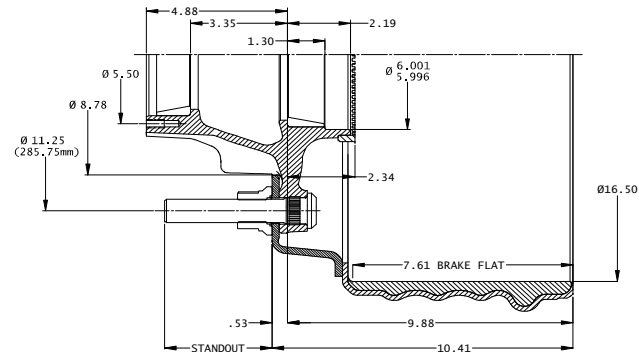

Walther Engineering and Manufacturing Co., Inc.

Part Number	Application	Standout	Lbs.	Bolts
TN Trailer Hub (Severe Duty)				
10-00042-001	Hub Piloted/Aluminum Dual Wheel	3.96"	48	02-00045
10-00042-002	Hub Piloted/Steel Dual Wheel	3.03"	47	02-00044
10-00042-003	Stud Piloted RH/Cast Brake Drum	1.88"	44	02-00057
10-00042-004	Stud Piloted LH/Cast Brake Drum	1.88"	44	20-00058
10-00042-005	Stud Piloted RH/Fused Brake Drum	1.63"	44	02-00061
10-00042-006	Stud Piloted LH/Fused Brake Drum	1.63"	44	20-00062
10-00042-101	ABS Hub Piloted/Aluminum Dual Wheel	3.96"	49	02-00045
10-00042-102	ABS Hub Piloted/Steel Dual Wheel	3.03"	48	02-00044
10-00042-103	ABS Stud Piloted RH/Cast Brake Drum	1.88"	45	02-00057
10-00042-104	ABS Stud Piloted LH/Cast Brake Drum	1.88"	45	20-00058
10-00042-105	ABS Stud Piloted RH/Fused Brake Drum	1.63"	45	02-00061
10-00042-106	ABS Stud Piloted LH/Fused Brake Drum	1.63"	45	20-00062

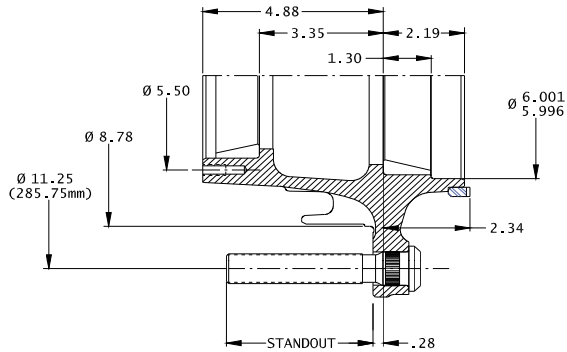

ALL WEIGHTS ARE BASED ON NOMINAL COMPONENT WEIGHT

TN Bearings				
HM212011	bearing cup - outer bore			
HM218210	bearing cup - inner bore			
HM212049	bearing cone - outer bore			
HM218248	bearing cone - inner bore			

Drums				
03-00043	16.5 x 7" Cast Brake Drum	108 lbs		
89996B	16.5 x 7" Centrifuse® Brake Drum	90 lbs		

Component Parts				
WN333T	Okabe - Two-piece, Flanged Wheel Nut,M22x1.5	.4 lbs		
02-39702	Metform - Two-piece, Flanged Wheel Nut,M22x1.5	.4 lbs		

Hub Dynamic Load Ratings	
Wheel Offset	Load/Hub
0	12,500 lbs
0.56"	12,043 lbs
2.00"	11,000 lbs
2.38"	10,765 lbs
2.75"	10,538 lbs
3.50"	10,105 lbs
3.88"	9,899 lbs
6.66"	7,300 lbs

Lubricant Fill Volumes	
15 fl-oz	Oil Lubrication Fill Level
61.40 in³	Vol. Between Cup Seats Including Spindle Displacement
17.01 fl-oz	50% Fill Level for Semi-Fluid, Including Spindle Displacement

Part Number	Application	Standout	Lbs.	Bolts
TN Trailer Hub (Severe Duty) with 16.5 x 7" Cast Drum				
10-00042-031*	Hub/Cast Drum Assy,HP,AL Whl	3.54"	161	02-00045
10-00042-032*	Hub/Cast Drum Assy,HP,ST Whl	2.61"	160	02-00044
10-00042-033	Hub/Cast Drum Assy,SP,RH	1.46"	157	02-00057
10-00042-034	Hub/Cast Drum Assy,SP,LH	1.46"	157	20-00058
10-00042-131*	ABS Hub/Cast Drum Assy,HP,AL Whl	3.54"	162	02-00045
10-00042-132*	ABS Hub/Cast Drum Assy,HP,ST Whl	2.61"	161	02-00044
10-00042-133	ABS Hub/Cast Drum Assy,SP,RH	1.46"	158	02-00057
10-00042-134	ABS Hub/Cast Drum Assy,SP,LH	1.46"	158	20-00058

* Includes two flanged wheel nuts

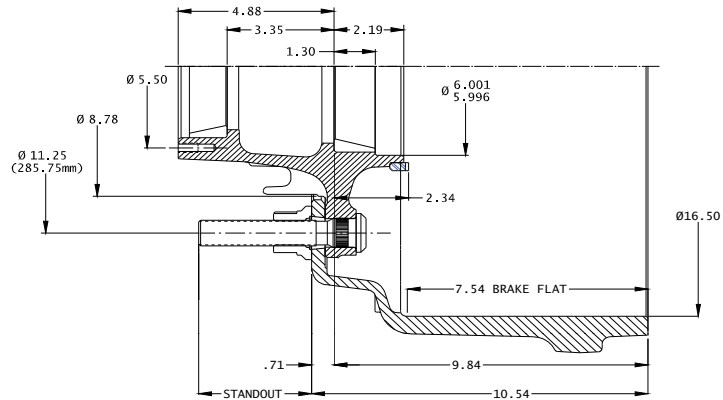

TN Trailer Hub (Severe Duty) with 16.5 x 7" Centrifuse® Brake Drum				
10-00042-041*	Hub/Fused Drum Assy,HP,AL Whl	3.71"	139	02-00045
10-00042-042*	Hub/Fused Drum Assy,HP,ST Whl	2.78"	138	02-00044
10-00042-045	Hub/Fused Drum Assy,SP, RH	1.38"	135	02-00061
10-00042-046	Hub/Fused Drum Assy, SP,LH	1.38"	135	20-00062
10-00042-141*	ABS Hub/Fused Drum Assy,HP,AL Whl	3.71"	140	02-00045
10-00042-142*	ABS Hub/Fused Drum Assy,HP,ST Whl	2.78"	139	02-00044
10-00042-145	ABS Hub/Fused Drum Assy,SP,RH	1.38"	136	02-00061
10-00042-146	ABS Hub/Fused Drum Assy,SP,LH	1.38"	136	20-00062

* Includes two flanged wheel nuts

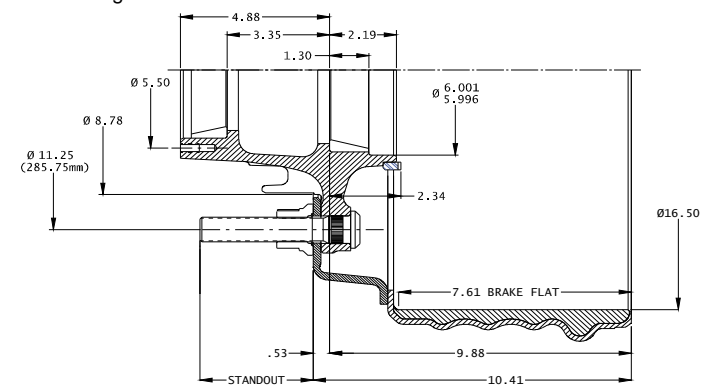

Walther Engineering and Manufacturing Co., Inc.

Part Number	Application	Standout	Lbs.	Bolts
TP Trailer Hub				
10-00052-001	Hub Piloted/Aluminum Dual Wheel	3.96"	51	02-00045
10-00052-002	Hub Piloted/Steel Dual Wheel	3.03"	50	02-00044
10-00052-003	Stud Piloted RH/Cast Brake Drum	1.88"	47	02-00057
10-00052-004	Stud Piloted LH/Cast Brake Drum	1.88"	47	20-00058
10-00052-005	Stud Piloted RH/Fused Brake Drum	1.63"	47	02-00061
10-00052-006	Stud Piloted LH/Fused Brake Drum	1.63"	47	20-00062
10-00052-101	ABS Hub Piloted/Aluminum Dual Wheel	3.96"	52	02-00045
10-00052-102	ABS Hub Piloted/Steel Dual Wheel	3.03"	51	02-00044
10-00052-103	ABS Stud Piloted RH/Cast Brake Drum	1.88"	48	02-00057
10-00052-104	ABS Stud Piloted LH/Cast Brake Drum	1.88"	48	20-00058
10-00052-105	ABS Stud Piloted RH/Fused Brake Drum	1.63"	48	02-00061
10-00052-106	ABS Stud Piloted LH/Fused Brake Drum	1.63"	48	20-00062

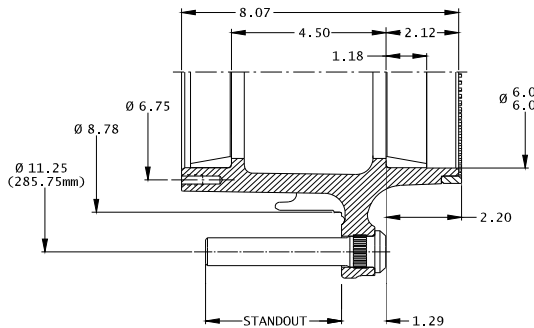

Part Number	Application	Standout	Lbs.	Bolts
TP Trailer Hub with 16.5 x 7" Cast Drum				
10-00052-031*	Hub/Cast Drum Assy,HP,AL Whl	3.54"	164	02-00045
10-00052-032*	Hub/Cast Drum Assy,HP,ST Whl	2.61"	163	02-00044
10-00052-033	Hub/Cast Drum Assy, SP, RH	1.46"	160	02-00057
10-00052-034	Hub/Cast Drum Assy, SP, LH	1.46"	160	20-00058
10-00052-131*	ABS Hub/Cast Drum Assy,HP,AL Whl	3.54"	165	02-00045
10-00052-132*	ABS Hub/Cast Drum Assy,HP,ST Whl	2.61"	164	02-00044
10-00052-133	ABS Hub/Cast Drum Assy, SP, RH	1.46"	161	02-00057
10-00052-134	ABS Hub/Cast Drum Assy, SP, LH	1.46"	161	20-00058

* Includes two flanged wheel nuts

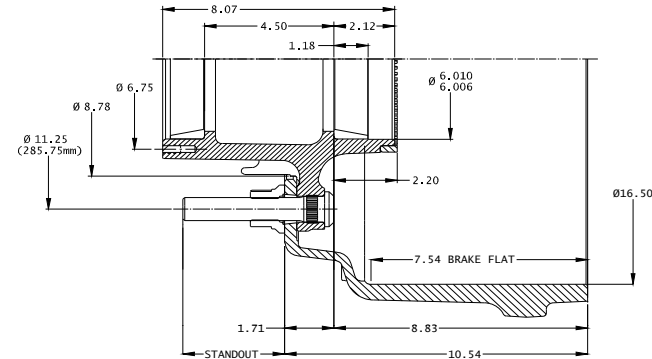

ALL WEIGHTS ARE BASED ON NOMINAL COMPONENT WEIGHT

TP Bearings		
HM518410	bearing cup - outer bore	
HM518410	bearing cup - inner bore	
HM518445	bearing cone	

Drums			
03-00043	16.5 x 7" Cast Brake Drum	108 lbs	
89996B	16.5 x 7" Centrifuse® Brake Drum	90 lbs	

Component Parts			
WN333T	Okabe - Two-piece, Flanged Wheel Nut,M22x1.5	.4 lbs	
02-39702	Metform - Two-piece, Flanged Wheel Nut,M22x1.5	.4 lbs	

Hub Dynamic Load Ratings		
Wheel Offset	Load/Hub	
0	12,500 lbs	
0.56"	12,043 lbs	
2.00"	11,000 lbs	
2.38"	10,765 lbs	
2.75"	10,538 lbs	
3.50"	10,105 lbs	
3.88"	9,899 lbs	
6.66"	7,300 lbs	

Lubricant Fill Volumes		
23 fl-oz	Oil Lubrication Fill Level	
94.0 in³	Vol. Between Cup Seats Including Spindle Displacement	
26.04 fl-oz	50% Fill Level for Semi-Fluid, Including Spindle Displacement	

TP Trailer Hub with 16.5 x 7" Centrifuse® Brake Drum				
10-00052-041*	Hub/Fused Drum Assy,HP,AL Whl	3.71"	139	02-00045
10-00052-042*	Hub/Fused Drum Assy,HP,ST Whl	2.78"	138	02-00044
10-00052-045	Hub/Fused Drum Assy,SP, RH	1.38"	135	02-00061
10-00052-046	Hub/Fused Drum Assy, SP,LH	1.38"	135	20-00062
10-00052-141*	ABS Hub/Fused Drum Assy,HP,AL Whl	3.71"	140	02-00045
10-00052-142*	ABS Hub/Fused Drum Assy,HP,ST Whl	2.78"	139	02-00044
10-00052-145	ABS Hub/Fused Drum Assy,SP,RH	1.38"	136	02-00061
10-00052-146	ABS Hub/Fused Drum Assy,SP,LH	1.38"	136	20-00062

* Includes two flanged wheel nuts

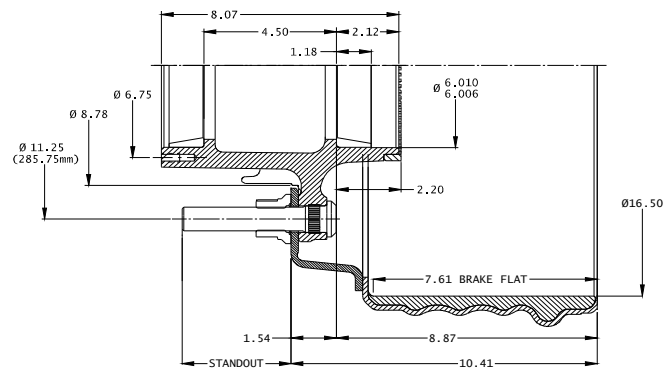

Walther Engineering and Manufacturing Co., Inc.

Part Number	Application	Standout	Lbs.	Bolts	Part Number	Application	Standout	Lbs.	Bolts
Low-Boy Trailer Hub					Low-Boy Trailer Hub with 12 1/4 x 7.5" Cast Drum				
10-00048-001	Hub HP, AL Whl	4.14"	40	02-00045	10-00048-031*	Hub/Cast Drum Assy. HP, AL Whl	3.64"	133	02-00045
10-00048-002	Hub HP, ST Whl	3.21"	39	02-00044	10-00048-032*	Hub/Cast Drum Assy. HP, ST Whl	2.71"	132	02-00044
10-00048-101	ABS Hub HP, AL Whl	4.14"	41	02-00045	10-00048-131*	ABS Hub/Cast Drum Assy. HP, AL Whl	3.64"	134	02-00045
10-00048-102	ABS Hub HP, ST Whl	3.21"	40	02-00044	10-00048-132*	ABS Hub/Cast Drum Assy. HP, ST Whl	2.71"	133	02-00044
					* Includes two flanged wheel nuts				
ALL WEIGHTS ARE BASED ON NOMINAL COMPONENT WEIGHT									
Hub Dynamic Load Ratings					Component Parts				
Wheel Offset	Load/Hub				03-00050	12 1/4" x 7.5" Cast Brake Drum	93 lbs		
0	10,000 lbs				WN333T	Okabe - Two-piece, Flanged Wheel Nut,M22x1.5	.4 lbs		
0.56"	N/A				02-39702	Metform - Two-piece, Flanged Wheel Nut,M22x1.5	.4 lbs		
2.00"	N/A				TN Bearings				
2.38"	N/A				HM212011	bearing cup - outer bore			
2.75"	N/A				HM218210	bearing cup - inner bore			
3.50"	N/A				HM212049	bearing cone - outer bore			
3.88"	N/A				HM218248	bearing cone - inner bore			
6.66"	N/A								
Lubricant Fill Volumes									
15 fl-oz	Oil Lubrication Fill Level								
61.40 in³	Vol. Between Cup Seats Including Spindle Displacement								
17.01 fl-oz	50% Fill Level for Semi-Fluid, Including Spindle Displacement								